

present, but it certainly does show that a nitrogen-containing group has been added to the resin. When all three of the forementioned studies are put together it seems reasonable to say that the hydroxamic acid resin has been formed.

The main purpose of this work was to prepare the chelate resin. As such, no distribution studies were made nor was every available ion passed through the column. However, several ions were tested to show that the chelate resin was indeed different from the

original resin. Table I shows the results of such a study. The first 9 ions have been reported previously to react with the hydroxamic acid group while the last two are not known to react with hydroxamic acids.

LITERATURE CITED

- (1) Calmon, Calvin, Kressman, T. R. E., "Ion Exchangers in Organic and Biochemistry," p. 122, Interscience, New York, 1957.
- (2) Gigiere, P. A., Liel, I. D., *Can. J. Chem.* **36**, 948-62 (1951).
- (3) Hadzi, D., *J. Chem. Soc.* **1956**, 2725.

- (4) Nightingale, R. E., Wagner, E. R., *J. Chem. Phys.* **22**, 203 (1954).
- (5) Renfrow, W. B., Jr., Hauser, C. R., *J. Am. Chem. Soc.* **59**, 2308 (1937).

GLENN PETRIE
DAVID LOCKE
CLIFTON E. MELOAN

Department of Chemistry
Kansas State University
Manhattan, Kan.

RECEIVED for review January 15, 1965.
Accepted March 29, 1965. The support of the National Science Foundation summer fellowship program is gratefully acknowledged.

Induction-Coupled Plasma Spectrometric Excitation Source

SIR: During the past two years we have employed various experimental configurations for forming plasmas of the inductively coupled type (9, 10) and have evaluated their potentialities as a source for the excitation of atomic and molecular spectra. One of these configurations was particularly useful as a practical source for analytical spectrometry. In this configuration, an induction coupled plasma is maintained by a high-frequency, axial magnetic field in a laminar flow of argon at atmospheric pressure. No electrodes are in contact with this discharge as opposed to the capacitively coupled plasma—i.e., high-frequency torch or radio-frequency discharge (6, 7)—and d.c. plasma jet. When the discharge gas in the induction-coupled plasma is pure argon, a temperature of about 16,000° K. is obtained at or near thermal equilibrium (9, 10). To contain a discharge of this temperature without wall contamination, a carefully controlled, laminar flow of cold argon surrounds the plasma. Atomic spectra are obtained by introducing ultrasonically generated aerosols into the argon flow which supports the plasma.

The recent appearance of a paper by Greenfield, Jones, and Berry (3) describing a similar source has prompted this communication on our independent observations. Our experimental arrangement for maintaining the plasma and for introducing an aerosol into the discharge is considerably different from the Greenfield design and possesses definite advantages for analytical applications.

The laminar flow of gas employed to support our plasma differs distinctly from other published induction-coupled designs. Single-tube versions described by Reed (9, 10), Cannon (2), Mironer and Hushfar (8), and Kana'an and co-workers (1, 4) have employed tangential

gas inlets to form vortex flows of high velocity at the walls and of low velocity in the center. The resulting recirculation of the hot gas was considered essential for operation of these designs. In the laminar-flow plasma described in this communication, there is no recirculation. In fact, a pure argon plasma has been operated on flow rates as high as 4.6 liters/minute in the plasma tube (which corresponds to a velocity of 38 cm./second) without any decrease in stability or intensity.

Tangential inlets are also used in both tubes of the dual-tube designs of Greenfield, Jones, and Berry (3) and

Lepel (Lepel High Frequency Laboratories, Woodside, N.Y.), but their designs possess several inherent disadvantages in comparison to the laminar-flow configuration. First, a vortex flow has more turbulence than a laminar flow and this turbulence may decrease the stability of the discharge. This loss of stability is drastically enhanced by minor distortions in the walls of the tubes, whereas our plasma has been operated successfully with the coolant tube purposely bent and kinked. Second, the addition of aerosols of solutions or powders to a tangential flow of gas tends to cause them or their vapors to be thrown against the inner wall of the coolant tube, thus decreasing the transmittance of the tube and devitrifying the quartz. Because the coolant flow in our design is laminar and mixes only slightly with the hot vapors in the core of the discharge, the coolant tube remains clean and useful throughout months of continuous use. The Forrest plasma torch (Forrest Electronics Corp., Las Vegas, Nev.) is the only other dual-tube, laminar-flow design to our knowledge, but no data have been published on its performance.

As shown in Figure 1, an ultrasonic atomizing system, similar in design to that of West and Hume (11), is used to produce an aerosol of the sample solution with an average droplet diameter of about 5 microns (5). These droplets are carried into the discharge by an independent stream of argon via a small central tube.

The ultrasonic aerosol generator allows the introduction of solutions of virtually any sample concentration (so long as the viscosity is not too high) and of any degree of acidity or basicity. Thus, absolute detection limits are greatly improved. Organic solvents may also be used if the sample container is made of an appropriate material.

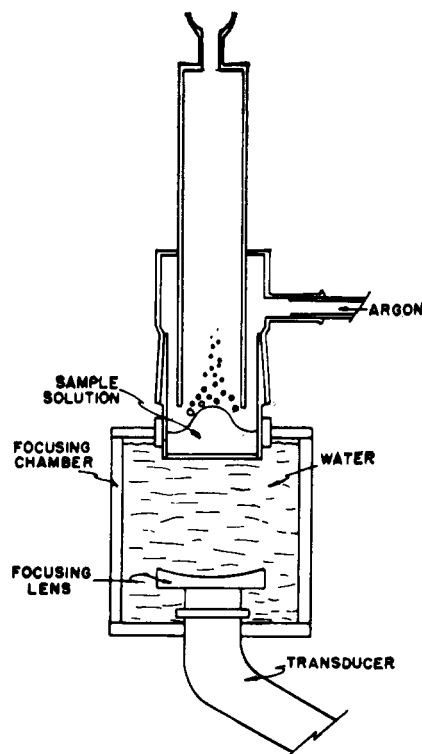

Figure 1. Aerosol generator

Although variations in viscosity, surface tension, and sample depth will slightly affect the production rate and droplet size of the aerosol, the primary factor controlling the rate of addition of aerosol to the plasma is the argon flow rate, which may easily be reproduced.

EXPERIMENTAL FACILITIES

Plasma. Power supply: Lepel High Frequency Laboratories, Woodside, N. Y. Model T-5-3-MC-J-S generator; 3.4-mc. frequency; 5-kw. nominal output.

Coil: Lepel pancake-concentrator type, 5 turn.

Coolant tube: clear fused quartz, 22-mm. i.d., 24-mm. o.d.; 22 cm. total length, extending 11 cm. beyond coil.

Plasma tube: clear fused quartz, 16-mm. i.d., 18-mm. o.d.; 12.5 cm. total length, terminating 17 mm. below top of concentrator ring; centered within coolant tube by four "feet" located 3 cm. from open end.

Aerosol tube: borosilicate glass, 5-mm. i.d., 7-mm. o.d., terminating 4 mm. below end of plasma tube.

Base: brass; double O-ring seals on each quartz tube; optional screen to ensure laminar flow.

Flow rates to discharge: coolant, 22 liters/minute of Ar; plasma, 0.4 liter/minute of Ar; aerosol, 0.5 liter/minute of Ar which carries 0.12 ml. solution/minute.

Ignition: graphite rod, not grounded; lowered into high field region until plasma is formed, then withdrawn.

Aerosol Generator. Power supply: Siemens (Siemed, Inc., Hinsdale, Ill.) Sonostat 631; 12-watt output from transducer; 870-kc. frequency.

Lens: acrylic plastic (Plexiglass), planoconcave; 7.5-cm. focal length; attached to transducer with Eastman 910 cement.

Sample container: inner glass joint, $\frac{1}{2}$ 50/50, with 0.010-inch Plexiglass bottom; 10- to 25-ml. capacity.

Aerosol chamber: borosilicate glass tube, 28-mm. o.d., 7 inches long, sealed into $\frac{1}{2}$ 50/50 outer glass joint.

Spectrograph. Jarrell-Ash, Boston, Mass., 1.5-meter Wadsworth Model 78.

OBSERVATIONS

The induction-coupled plasma has the general appearance of a bright flame with three regions or zones. The core or first region, as outlined in Figure 2, is centered at the top of the concentrator ring, and is about 8 mm. in diameter, 25 mm. long, nontransparent, and brilliant. The core fades into the second region which is about 16 mm. in diameter and about 75 mm. long (depending to a great degree on the length of the coolant tube and whether aerosol is being added). The second region is also bright but slightly transparent. The third region or tailflame is distinctly separated from and extends about 15 cm. above the tip of the second region.

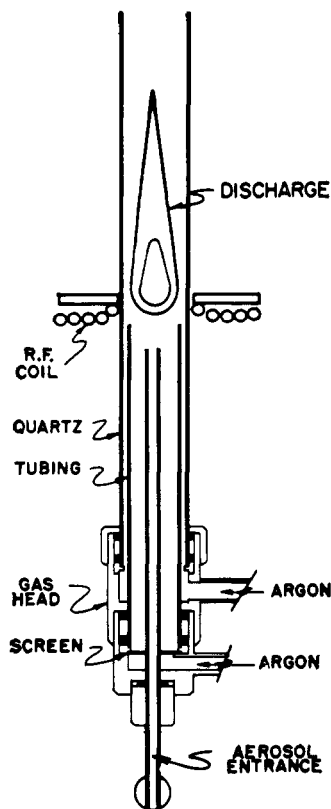

Figure 2. Plasma torch

When the plasma is supported by pure argon, the tailflame is barely visible because the strong argon emission lines are outside the range of sensitivity of the eye. The tailflame assumes typical flame colors when solutions are added to the plasma.

The radiation from the core includes an intense continuum extending from about 3000 to 5000 Å. which apparently arises from recombination and perhaps cyclotron radiation. The intensity of the continuum is sharply reduced in the second region and is negligible in the tailflame. A fairly well developed spectrum of neutral argon is emitted from the core and second region but only two Ar II lines (4806 and 7589 Å.) have been observed and these were weak even from the center of the core. The stronger Ar I lines are weak but still detectable in the tailflame more than 7 cm. above the tip of the second region. Because these lines have excitation potentials of 13.0 to 14.5 e.v., a significant concentration of argon atoms in the metastable state probably exists in the tailflame.

When an aqueous aerosol is introduced into the discharge, the over-all intensity of the plasma is reduced somewhat and the expected hydrogen Balmer-series lines and the 3064-Å. OH band system appear in the spectrum. The hydrogen lines are strong and broad in the core, but become sharper and weaker in the second region, and

disappear entirely before the tailflame begins. The OH band head at 3064 Å. is of moderate and relatively constant intensity throughout all three regions. The other OH band heads are weak or not visible in a normal exposure of the emission spectrum.

The portion of the tailflame which extends beyond the coolant tube emits band systems of O₂, N₂, NH, and N₂⁺ in addition to OH bands. When the coolant tube is short—e.g., Greenfield, Jones, and Berry—the second region also extends into the atmosphere and these band systems, especially N₂⁺, become considerably more intense. The discharge outside the tube, especially the tailflame, wanders slightly because of air currents and cannot be expected to have a stability as high as the discharge within the tube.

Neutral atom lines of most elements exhibit their best line to background ratio approximately 9 cm. above the core. High energy neutral atom lines and most ion lines exhibit their best ratio at 4.5 cm. above the core although for many elements the ratio is not significantly different.

Typical detection limits for a representative list of elements in aqueous solutions are given in Table I. The detection limit is defined here as that minimum concentration in solution which emits a detectable spectral line observable over the background.

The observation that useful lines of most elements can be detected at trace concentration levels indicates a wide range of analytical applications of this discharge. The use of aqueous solutions rather than organic solvents eliminates the band systems of C₂ and CH from the

Table I. Detection Limits of Elements

Element	Line, Å.	Detection limit, $\mu\text{g./ml.}$	
		4.5 cm.	9.0 cm.
Al	3961	3	3
As	2780	25	
Ca	4226	0.5	0.2
	3933	0.5	0.8
Cd	3261		20
Cr	3578		0.3
Cu	3247	1.2	0.2
Fe	3719		3
La	4086	50	50
Mg	2852	2	2
Mn	4030	2	1
Ni	3524		1
P	2535	10	
Si	2516	3	
Sn	3034	50	50
Sr	4607	0.09	0.09
Ta	2685	16	
Th	4019	40	40
W	4008	3	3
Zn	4810	30	
Zr	3438	15	15

emission spectra of the discharge. The background spectrum is thus low, especially from within the coolant tube. In addition, the discharge offers a wide range of excitation energy for special applications. Greenfield, Jones, and Berry (3) have confirmed our expectations that matrix effects are negligible. Although only a convenience advantage, the discharge emits considerably less audible noise than a Beckman burner or a constricted d.c. arc plasma jet. Our observations indicate that this combination of plasma and aerosol generator is a practical and versatile source for analytical spectrometry. We are now exploring further analytical applications and will discuss these in a more complete communication.

LITERATURE CITED

- (1) Beguin, C. P., Kana'an, A. S., Margrave, J. L., *Endeavor* **23** (89), 55 (1964).
- (2) Cannon, H. R., "A Study of an Induction-Coupled Plasma Operating at 400 Kilocycles," M.S. thesis, Air Force Institute of Technology, Wright-Patterson AFB, Ohio, GA/Phys/62-2, AD-286404 (1962).
- (3) Greenfield, S., Jones, I. L., Berry, C. T., *Analyst* **89**, 713 (1964).
- (4) Kana'an, A. S., "Studies at High Temperature," Ph.D. thesis, University of Wisconsin, Madison, Wis., 1963.
- (5) Lang, R. J., *J. Acous. Soc. Am.* **34**, 6 (1962).
- (6) Mavrodineanu, R., Hughes, R. C., *Spectrochim. Acta* **19**, 1309 (1963).
- (7) Mavrodineanu, R., Boiteux, H., "Flame Spectroscopy," pp. 51-3, Wiley, New York, 1965.
- (8) Mironer, A., Hushfar, H., "Radio

- Frequency Heating of a Dense, Moving Plasma," presented at AIAA Electric Propulsion Conference, Colorado Springs, Colo., (March 1963); preprint 63045-63, American Institute of Aeronautics and Astronautics, New York, N. Y.
- (9) Reed, T. B., *Intern. Sci. Technol.* (6), 42 (1962).
 - (10) Reed, T. B., *J. Appl. Phys.* **32**, 821 (1961).
 - (11) West, D. C., Hume, D. N., *ANAL. CHEM.* **36**, 412 (1964).

RICHARD H. WENDT
VELMER A. FASSEL

Institute for Atomic Research and
Department of Chemistry
Iowa State University
Ames, Iowa

RECEIVED for review February 24, 1965.
Accepted April 1, 1965. Work was performed in the Ames Laboratory of the U. S. Atomic Energy Commission.

CORRESPONDENCE

Application of Electrolytic Moisture Meter to Measurement of Water Vapor Transmission through Plastic Films

SIR: The water vapor transmission (WVT) of plastic films is commonly determined by a method, such as ASTM E96-53T, which measures weight of water passing through a film sample under specified conditions. This procedure cannot be applied to thick films or to materials with a very low water vapor transmission rate, because the weight of water passed in a reasonable time is too small to measure accurately. It appeared that very sensitive measurement of WVT would be possible with the P_2O_5 electrolytic cells developed by Keidel (2), and an instrument was designed and built for this purpose. This report describes the instrument and its application to the measurement of water vapor transmission rates.

EXPERIMENTAL

P_2O_5 Electrolytic Cells. The electrolytic cells used in this instrument were purchased from the Consolidated Electrochemicals Co., Pasadena, Calif. A thorough description of their construction and operation is contained in papers by Keidel and others (1, 2). These cells quantitatively electrolyze the water vapor contained in a gas stream passing through them, and the measured electrolysis current is converted to weight of water per unit time by application of Faraday's Law. Sensitivity of measurement is such that water diffusion rates of the order of micrograms per hour can be measured when the cell is connected to the water vapor transmission cell described below.

Water Vapor Transmission Cell. The sample cell consists of two compartments separated by the film whose WVT is being measured. The lower compartment is maintained at a known, constant water vapor content (usually 100% relative humidity). The upper compartment is continuously swept with a stream of dry nitrogen which maintains it at essentially zero relative humidity and carries the water diffusing through the film into the P_2O_5 cell for measurement. (Although the instrument reading is reasonably independent of nitrogen flow, the rate is maintained at 90-100 cc./minute to ensure rapid removal of

water vapor from the upper compartment.)

A series of concentric lands and grooves machined into the faces of the two halves of the cell to give a cross-section

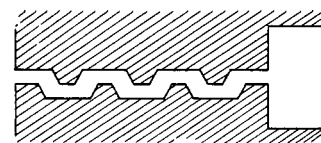

forms a leak-free seal when a plastic film is clamped between the faces of the cell.

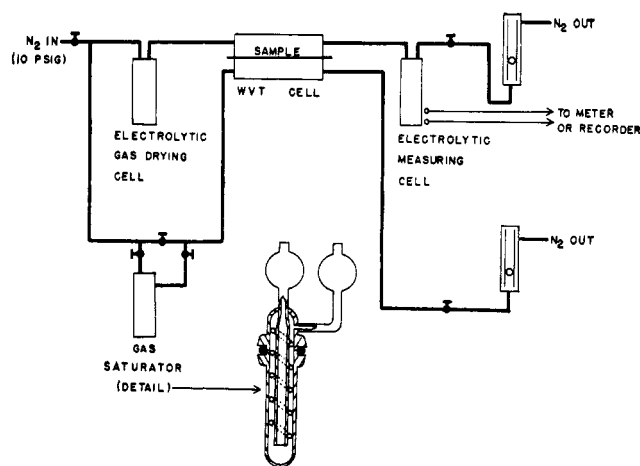

Figure 1. Block diagram of WVT instrument and detail of saturator